

# Swinghandle Lock 1205

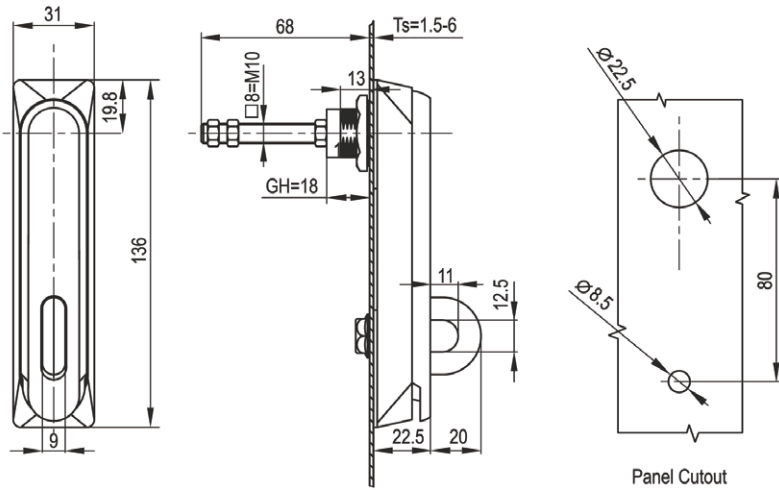

Stainless steel 304 or 316.

	SS304	SS316
Padlockable	1205-304	1205-316

# Swinghandle Lock 1209

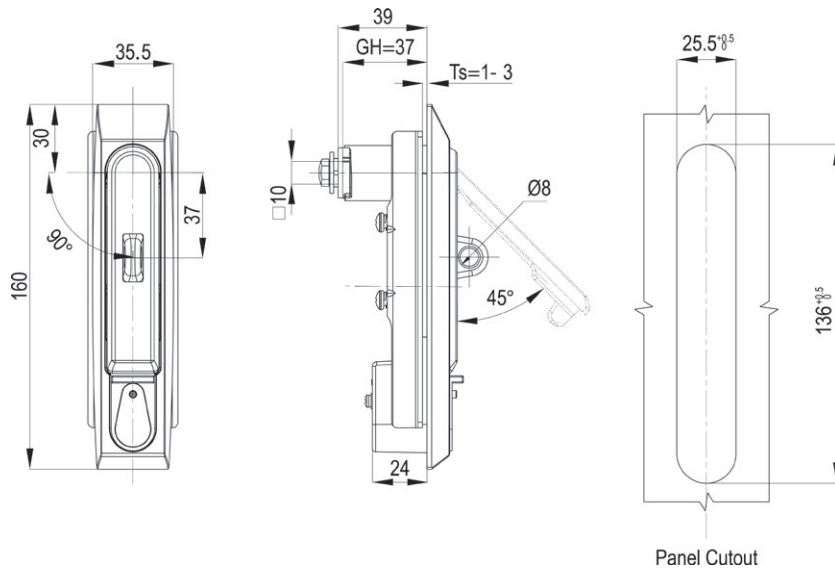

Zinc die (black powder coated), stainless steel padlock and mounting bracket.

Black Powder Coated	
Padlockable	1209-101-10-P
Without Padlock	1209-101-10

Cam ref. page 232.