

Zinc die handle and housing (black powder coated or bright chrome), zinc plated cam.

Insert Type	GH=30		GH=50	
	Bright Chrome	Black Textured Powder Coated	Bright Chrome	Black Textured Powder Coated
Key Locking	1402-30110-30	1402-30110-20	1402-50110-30	1402-50110-20
Non Locking	1402-30100-30	1402-30100-20	1402-50100-30	1402-50100-20

Accessories ref. to page 238. Cam ref. page 232.

Remark: 1. Keyed KEY333.

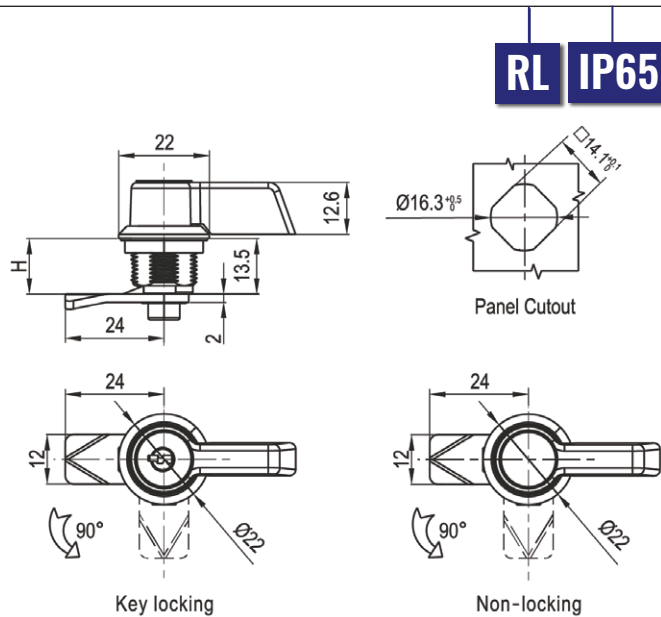

Zinc die handle and housing (black powder coated or bright chrome).
Mild steel zinc plated cam.

	H	Black Textured Powder Coated	Bright Chrome
	Non Locking	H=7.5	1402-400-20.107.5
H=13.5		1402-400-20.1013.5	1402-400-30.1013.5
H=19.5		1402-400-20.1019.5	1402-400-30.1019.5
Key Locking	H=7.5	1402-410-20.107.5	1402-410-30.107.5
	H=13.5	1402-410-20.1013.5	1402-410-30.1013.5
	H=19.5	1402-410-20.1019.5	1402-410-30.1019.5

Remark 1. Keyed 2233.