

Zinc die (black powder coated or bright chrome), mild steel zinc plated cam.

Black Powder Coated	Bright Chrome
1417-110-10	1417-110-30

Remark 1. Spring loaded mechanism.

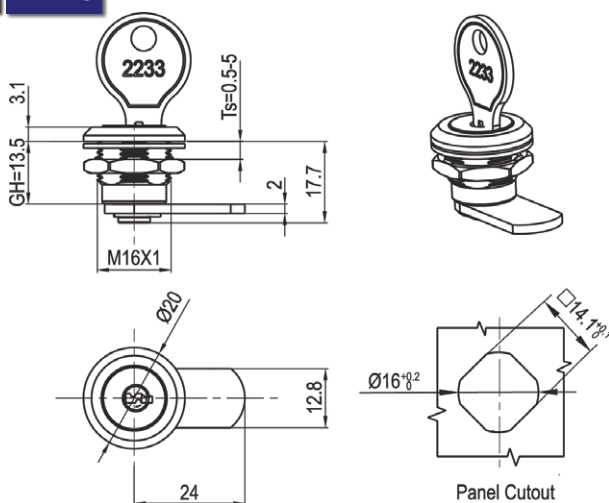

Zinc die (black powder coated or bright chrome), mild steel zinc plated cam.

Grip Height (GH)	Black Textured Powder Coated	Bright Chrome
H=7.5	1418-1-20.117.5	1418-1-30.117.5
H=13.5	1418-1-20.1113.5	1418-1-30.1113.5
H=19.5	1418-1-20.1119.5	1418-1-30.1119.5

Remark 1. Keyed 2233.