



Rod Control Swinghandle 1123



SWINGHANDLES



Cam control

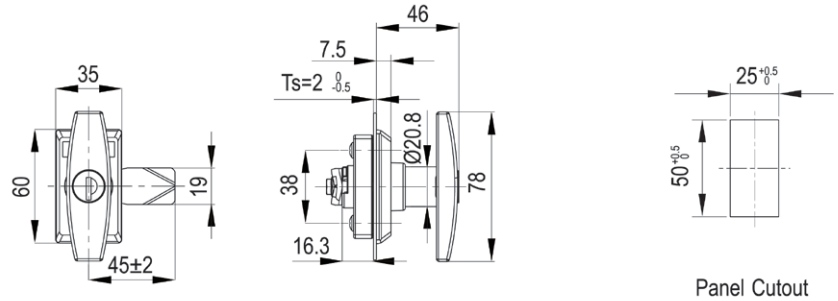

Panel Cutout



Rod control

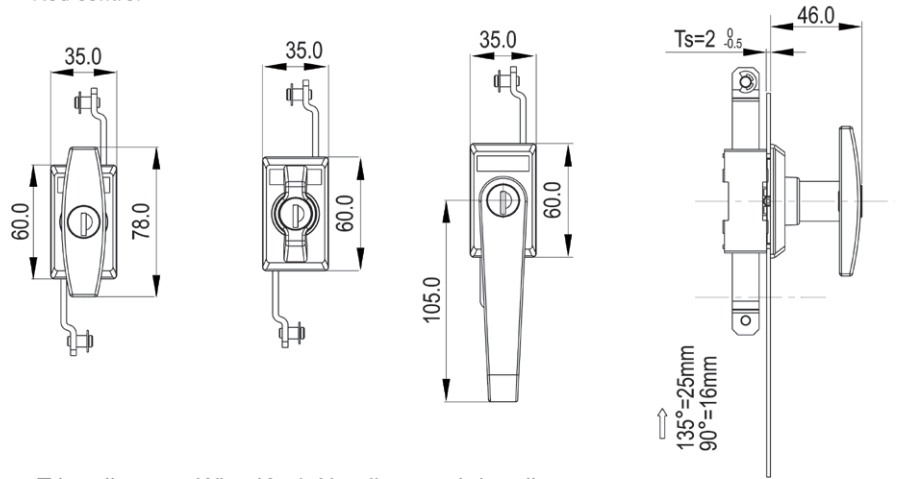

T-handle

Wing Knob Handle

L-handle

Zinc die housing and handle (black powder coated), mild steel zinc plated or SS304.

Handle Type	Version A (Cam Control)		Version B (2p. Rod Control)		Version C (3p. Rod Control)	
	Non-Locking	Key Locking	Non-Locking	Key Locking	Non-Locking	Key Locking
T-handle	1123-1000-S190	1123-1001-S190	1123-2000-S190	1123-2001-S190	1123-3000-S190	1123-3001-S190
L-handle	1123-1000-S290	1123-1001-S290	1123-2000-S290	1123-2001-S290	1123-3000-S290	1123-3001-S290
Wing Knob Handle	1123-1000-S390	1123-1001-S390	1123-2000-S390	1123-2001-S390	1123-3000-S390	1123-3001-S390

Accessories ref. page 238. Cam ref. page 232. Rod control 1192 series ref. page 46.

Remark 1. Keyed KEY333. 2. CH751 keyed on request. 3. Key different on request.

www.metrolmotion.com