

Zinc die housing and cylinder (black powder coated or bright chrome).
Mild steel zinc plated cam and shaft.

Shaft Style	Head Style	
	Key Locking	Non-Locking
Short Shaft	1439-110-S20	1439-100-S20

Remark 1. Keyed CH751 key.

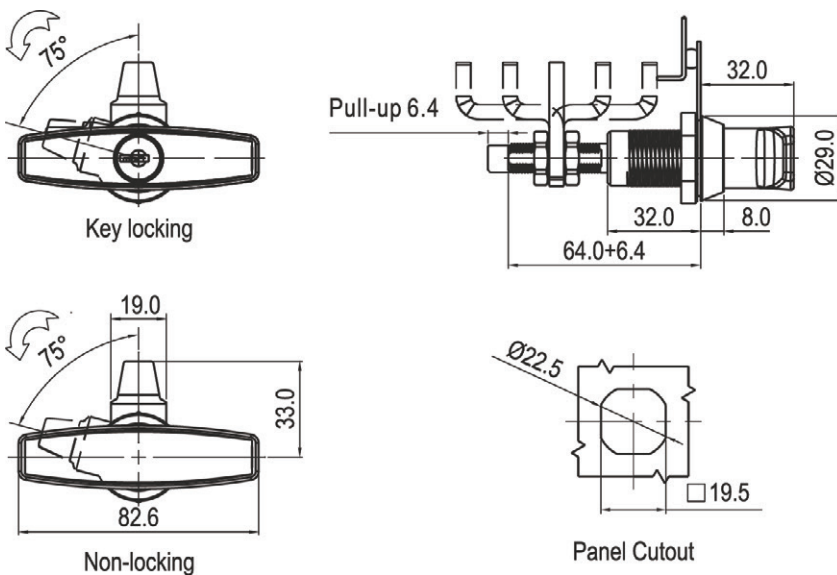

Zinc die housing and cylinder (black powder coated or bright chrome).
Mild steel zinc plated cam and shaft.

Shaft Style	Cam Style BH	Grip Range		Head Style	
		Min	Max	Key Locking	Non-Locking
Long Shaft	Reversed Cam	11.4	27.2	1439-110-L1520	1439-100-L1520
		25.4	41.1	1439-110-L2520	1439-100-L2520
	Straight Cam	38.9	54.6	1439-110-L3520	1439-100-L3520
		52.6	68.3	1439-110-L2520	1439-100-L2520
		66.3	76.2	1439-110-L1520	1439-100-L1520

Remark 1. Keyed CH751 key.