

Screw on version

Weld on version

Mild steel zinc plated or SS304.

	SS304	Steel
Screw-On Version	2406-011-304	2406-011-01
Weld-On Version	2406-012-304	2406-012-01

Remark: 1. 2x M4 threaded holes for screw-on version. 2. 2x 3.2mm through holes for weld-on version.

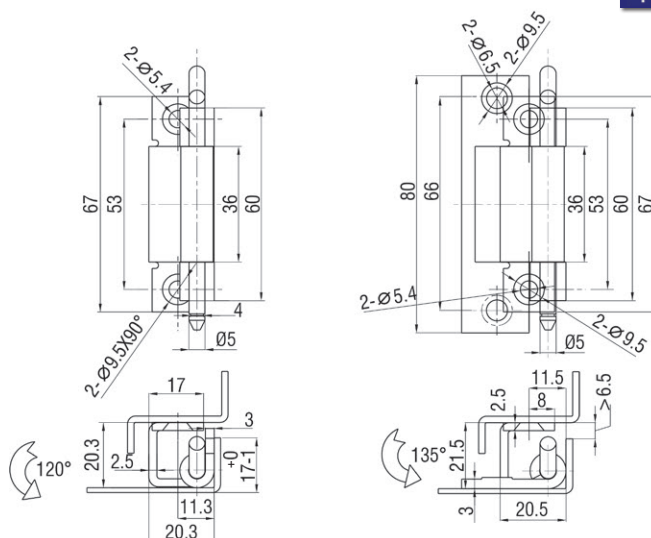

Mild steel zinc plated or SS304.

	SS304	Steel
Weld-On Version	2407-011-304	2407-011-01
Screw-On Version	2407-012-304	2407-012-01