

# Snap-In Slide Latch 1252/1254

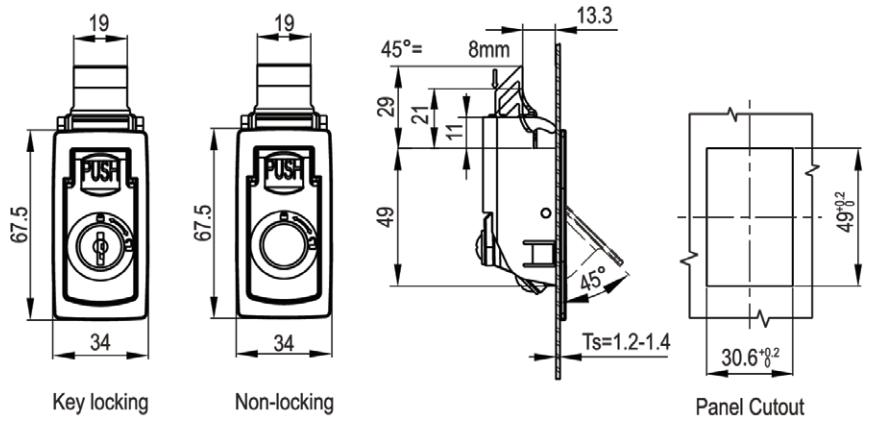

Black polyamide and glass fibre reinforced (GF).

|                 |         |
|-----------------|---------|
| Key Locking     | 1252-10 |
| Non-Key Locking | 1252-00 |

Remark 1. Keyed KEY333.

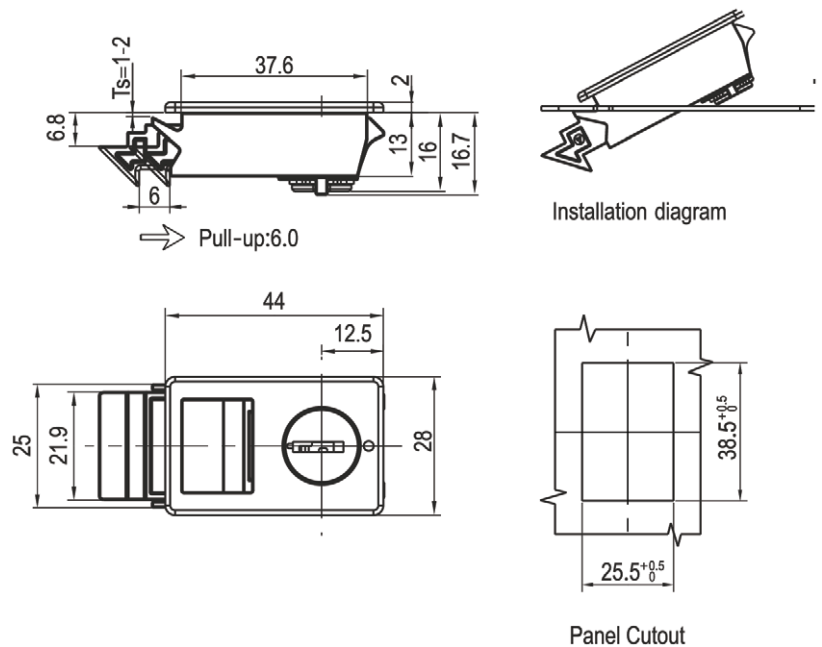

Black polyamide housing, cam and insert.

|          |         |
|----------|---------|
| Black PA | 1254-20 |
|----------|---------|

Remark 1. Keyed KEY333.