



Screw-On Torque Hinge 2136



TORQUE HINGES

Countersunk Screw M8

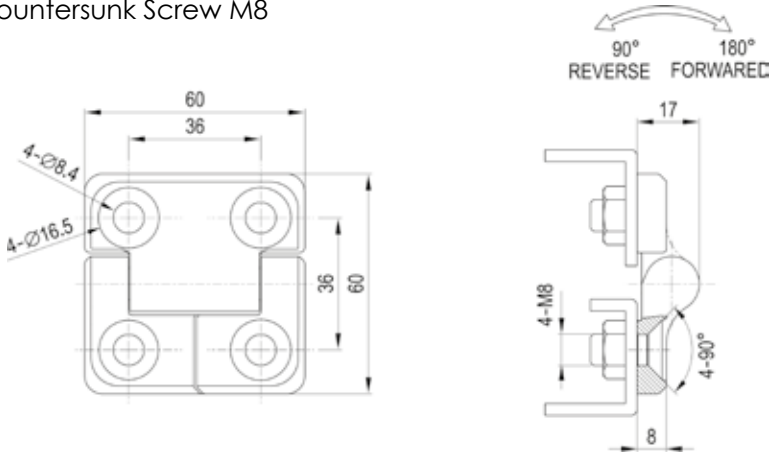

With Threaded Studs M8

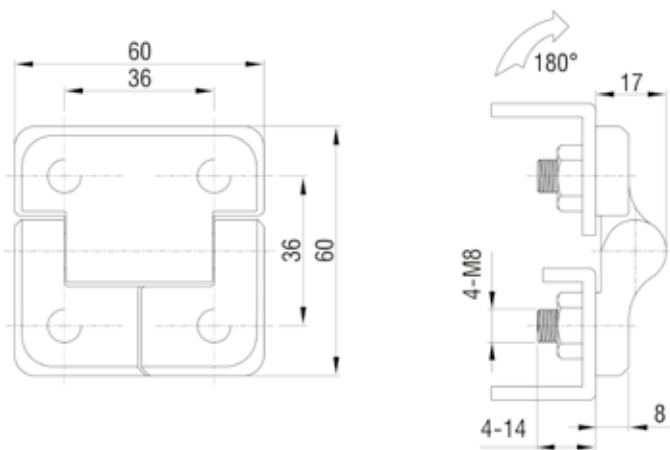

Zinc screw-on torque hinge, stainless steel pin. Asymmetric N.m.

Black Textured Powder Coated		
N.m.	Countersunk Screw M8	With Threaded Studs M8
Free Operating	2136-6000-20	2136-6100-20
1.36	2136-6013-20	2136-6113-20
2.26	2136-6022-20	2136-6122-20
3.16	2136-6031-20	2136-6131-20
4.07	2136-6040-20	2136-6140-20

Black Textured Powder Coated			
Forward Torque N.m	Reverse Torque N.m	Countersunk Screw M8	With Threaded Studs M8
2.3	1.4	2136-6023F-20	2136-6123F-20
3.2	1.9	2136-6032F-20	2136-6132F-20
4.1	2.4	2136-6041F-20	2136-6141F-20
5	3	2136-6050F-20	2136-6150F-20
1.4	2.3	2136-6019R-20	2136-6114R-20
1.9	3.2	2136-6027R-20	2136-6119R-20
2.4	4.1	2136-6024R-20	2136-6124R-20
3	5	2136-6030R-20	2136-6130R-20

CYCLE LIFE: Within 25,000 cycles static torque stay. Within ± 20% of torque specification.



www.metrolmotion.com